

"CAM-LOCK" PANEL to PANEL CONNECTION

Plan View

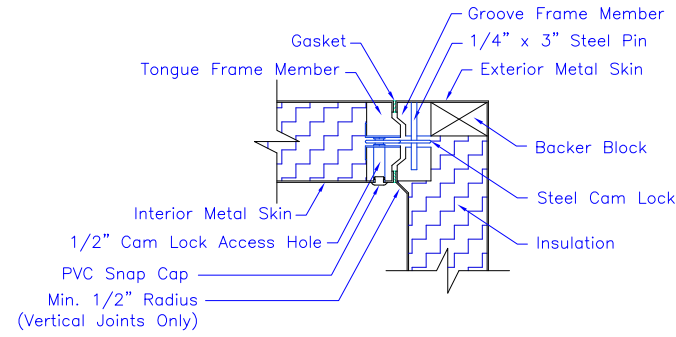

"CAM-LOCK" PANEL CORNER CONNECTION

Plan View

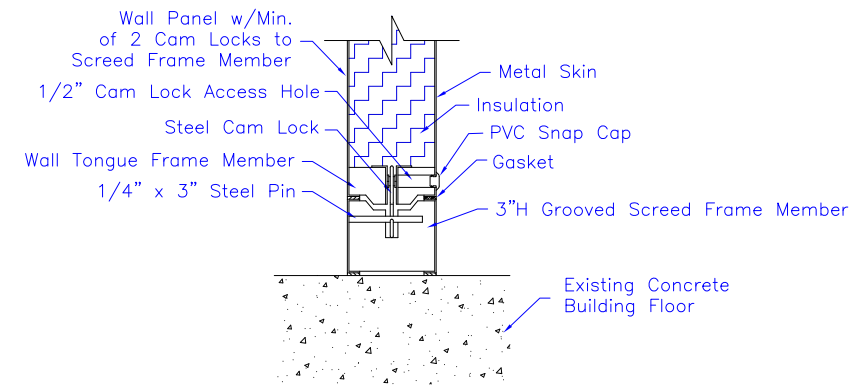

WALL to SCREED CONNECTION

Side View

**CONTACT FACTORY FOR
ADDITIONAL DETAILS**

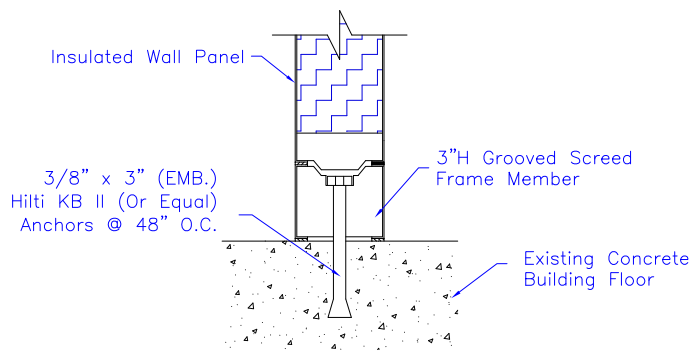

COLD ROOM SCREED to BUILDING FLOOR CONNECTION

Side View

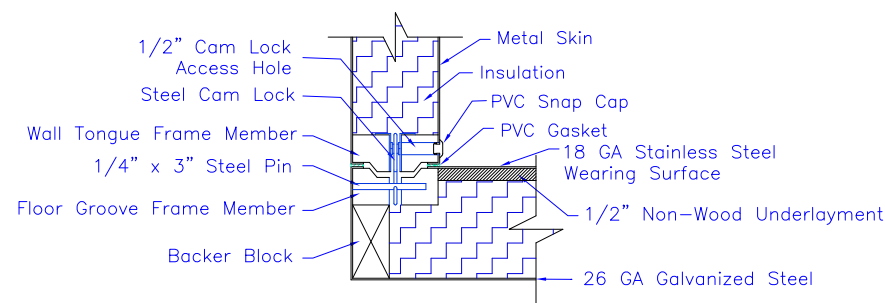

FLOOR PANEL to WALL PANEL CONNECTION

Side View

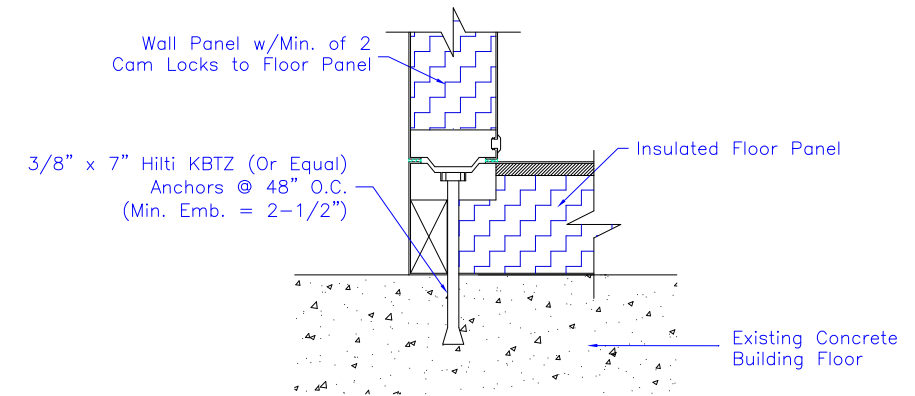

FLOOR PANEL to BUILDING FLOOR CONNECTION

Side View

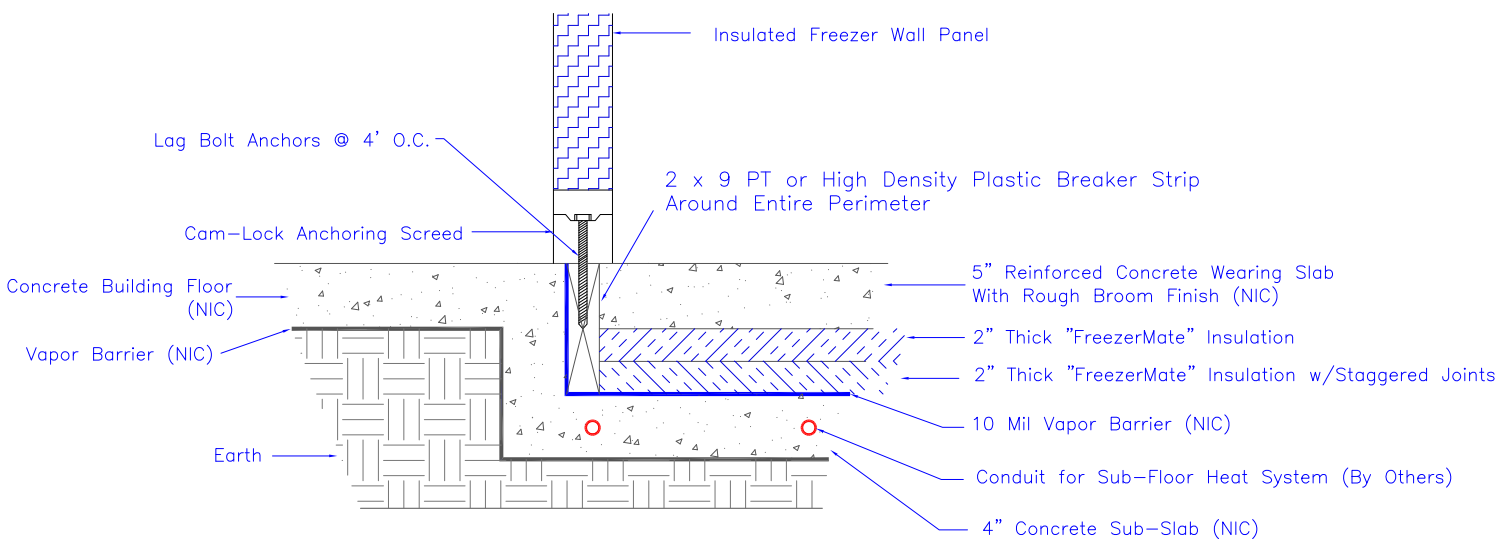

FREEZER SCREED TO BUILDING FLOOR CONNECTION

Side View

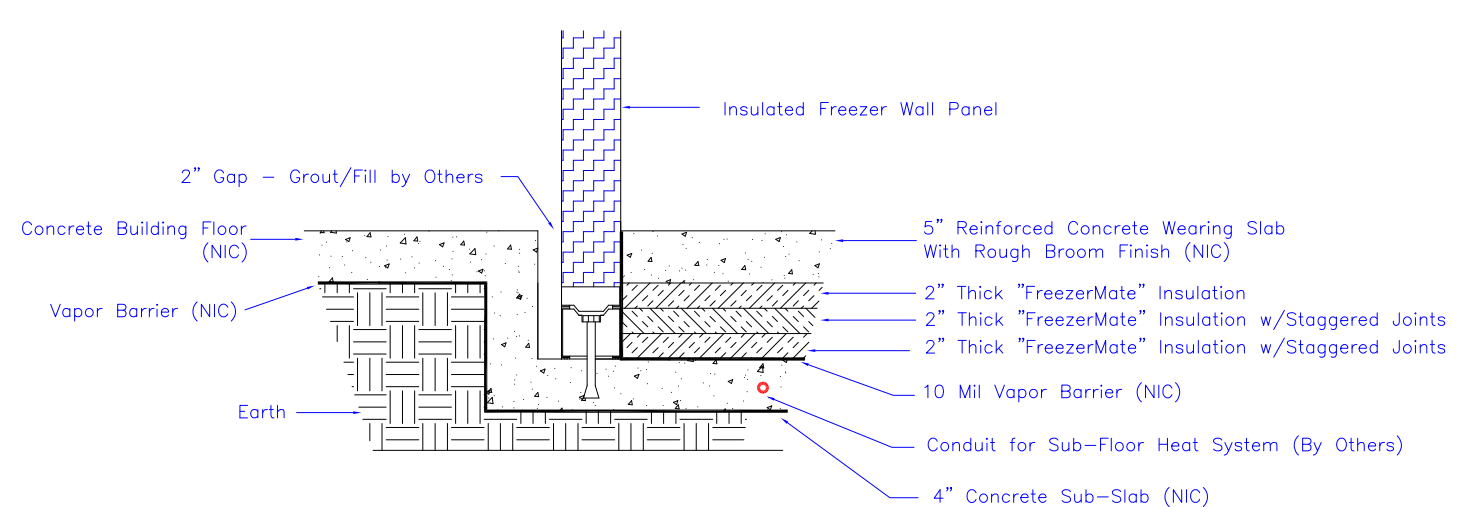

FREEZER SCREED TO BUILDING FLOOR CONNECTION

Side View

COLD ROOM SOLUTIONS
3942 Valley Ave., Suite L, Pleasanton, CA 94566
(925) 462-2500 FAX (925) 462-2502
www.coldroomsolutions.com



TYPICAL DETAILS

SCALE:

None

Job No.: Dwg. By:

Date: Dwg. No.: